

**EN**  
**ASSEMBLY INSTRUCTIONS OUTDOOR GAS PIZZA OVEN**

Grilldepot PRO 16 pizza oven  
VMP-16AS

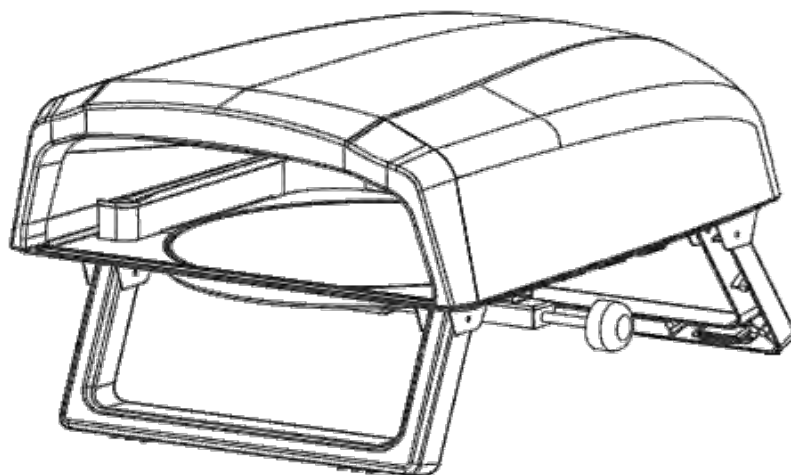

P.I.N Code: 2531DM-0118

**USE OUTDOORS ONLY**

**PLEASE READ INSTRUCTIONS CAREFULLY BEFORE ASSEMBLY  
RETAIN THIS MANUAL FOR FUTURE REFERENCE**

**Warning**

**If you smell gas, turn off the gas supply at the gas cylinder immediately.**

## WARNING

### **Hazardous fire or explosion may result if instructions are ignored**

It is the consumer's responsibility to see that the barbecue is properly assembled, installed, and taken care of. Failure to follow instructions in this manual could result in bodily injury and/or property damage.

### **Read the instructions before using the appliance.**

Retain this manual for future reference.

Use outdoors only.

Warning accessible parts may be very hot. Keep young children away.

Do not move the appliance during use.

Turn off the gas supply at the gas cylinder after use.

Do not modify the appliance.

This appliance must be kept away from flammable materials during use.

The regulator and hose must be connected correctly to the appliance. A spanner must be used to tighten the nut onto the connection thread.

### **FOR YOUR SAFETY IF YOU SMELL GAS:**

1. Turn off gas supply at gas cylinder.
2. Extinguish all naked flames; do not operate any electrical appliances.
3. Ventilate the area.
4. Check for leaks as detailed in this manual.
5. If odour persists, contact your dealer or gas supplier immediately.

### **PRECAUTIONS:**

1. Leak test all connections **after each cylinder refill or before each use.**
2. Never check for leaks with a match or open flame.
3. Do not store or use gasoline or other flammable vapors and liquids in the vicinity of this or any other appliance.
4. Any gas cylinder not connected for use shall not be stored in the vicinity of this or any other appliance.

## Assembly

**WARNING:** Whilst every effort has made in manufacture of your pizza oven to remove any sharp edge, you should handle all components with care to avoid accidental injury.

**Tools may required:** Either a Philips crosshead or flat-bladed screwdriver and either a spanner or a pair pliers.

### **ASSEMBLY:**

**Please read all instructions thoroughly before proceeding. Find a large, clean area in which to assemble your gas pizza oven. Please refer to the parts list and assembly diagram as necessary.**

**NOTICE:** Make sure all the plastic protection rip off before assembling!

## Explosive view

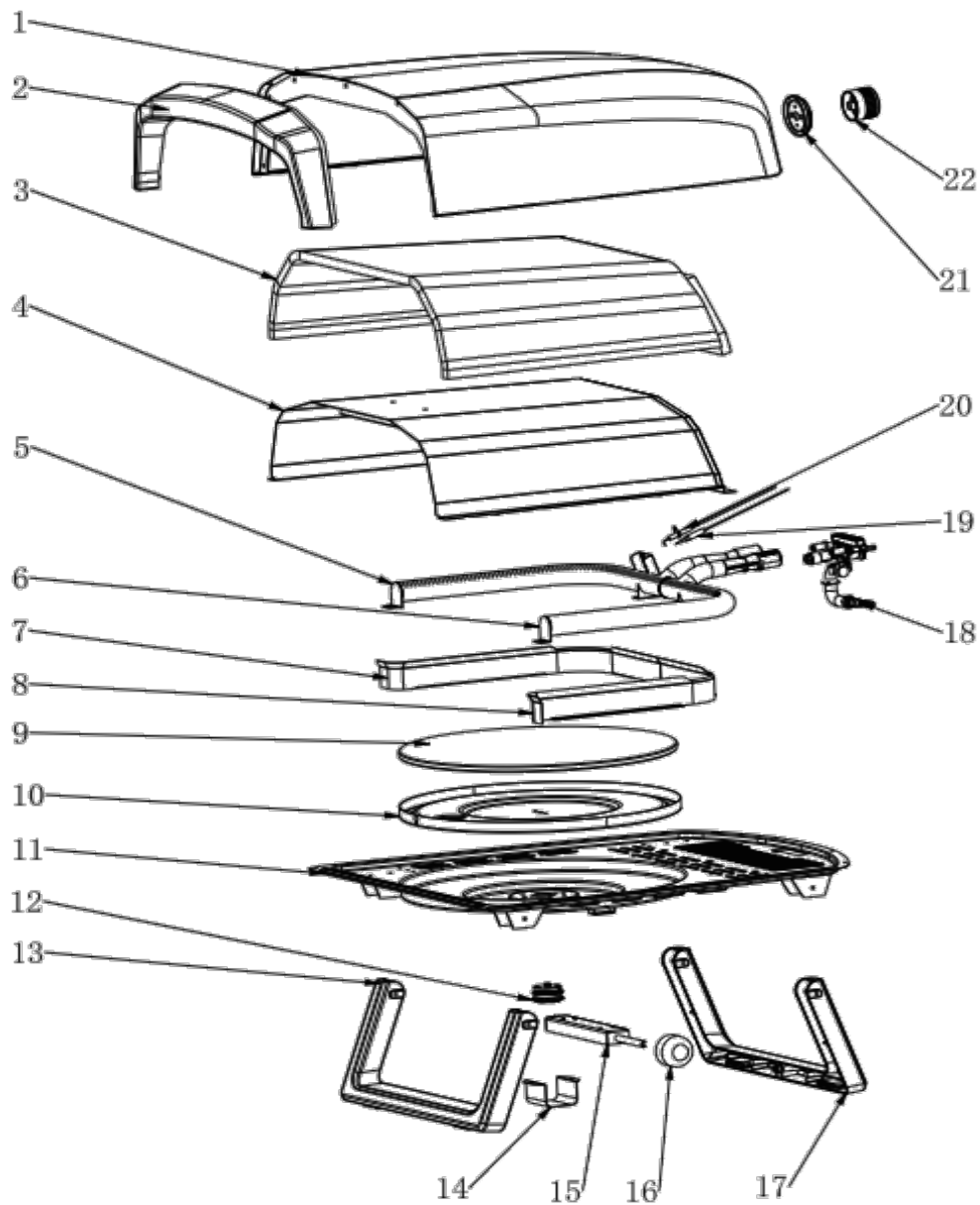

## Part list

NO.	Description	Qty	NO.	Description	Qty
1	Shell	1	13	Foot A	1
2	Frontage	1	14	Cover	1
3	Insulation	1	15	Turning assembly	1
4	inner	1	16	Knob	1
5	Burner A	1	17	Foot B	1
6	Burner B	1	18	Valve	1
7	Plate A	1	19	Thermocouple	1
8	Plate B	1	20	Ignition	1
9	Pizza Stone	1	21	Knob base	1
10	Pizza Plate	1	22	Knob	1
11	Base	1			
12	Gear assembly	1			

## ASSEMBLY :

Before assembly, please make sure all parts are present. If any part is missing or damaged, do not attempt to assemble the appliance. Contact customer service for replacement parts.

### 1: Unfold legs

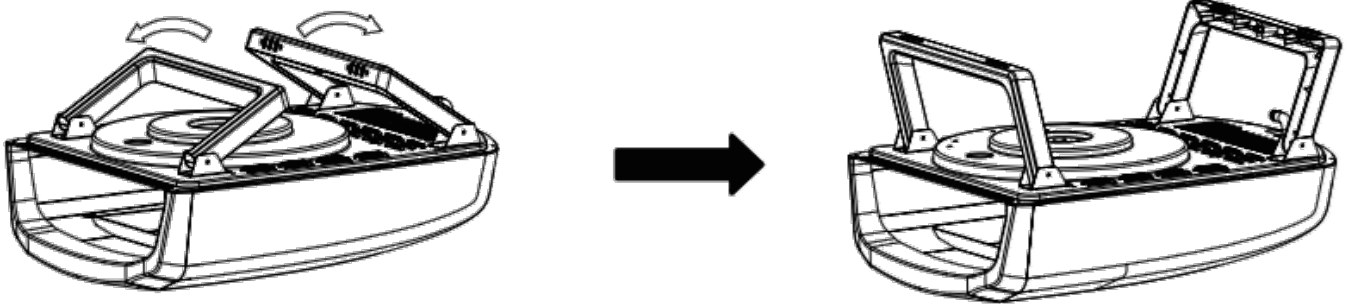

### 2: Insert the pizza stone

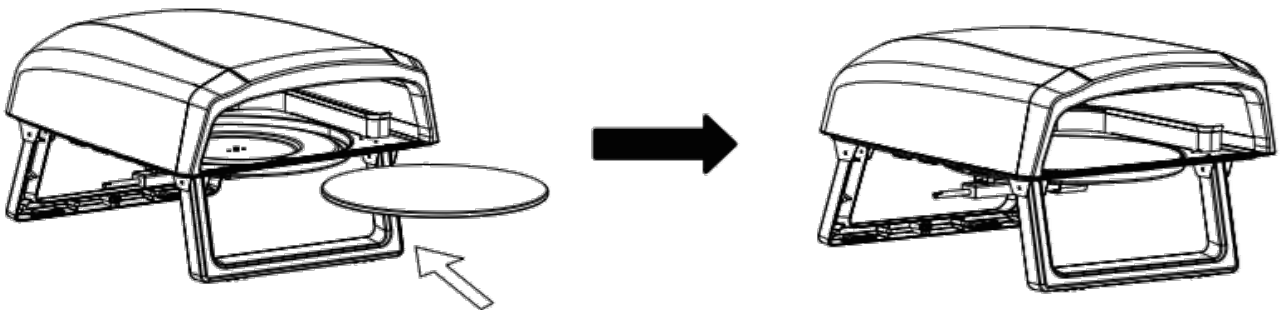

### 3: Fix knob

Please take the knob out and follow below guide to insert your knob to the pizza oven.

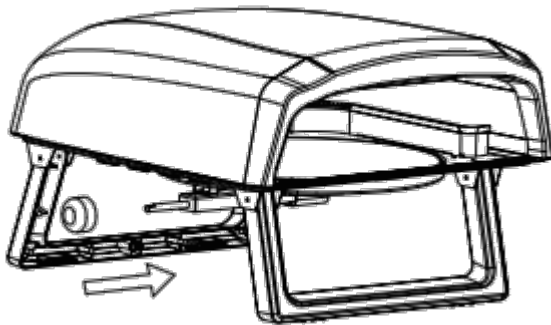

### 4 Connection regulator and hose to pizza oven.

Please note the factory setting that the regulator and hose will not be assembled to the oven. Before use the pizza oven please make sure your regulator&hose are in compliance with local standard. Then you can connect it to the pizza oven and gas tank.

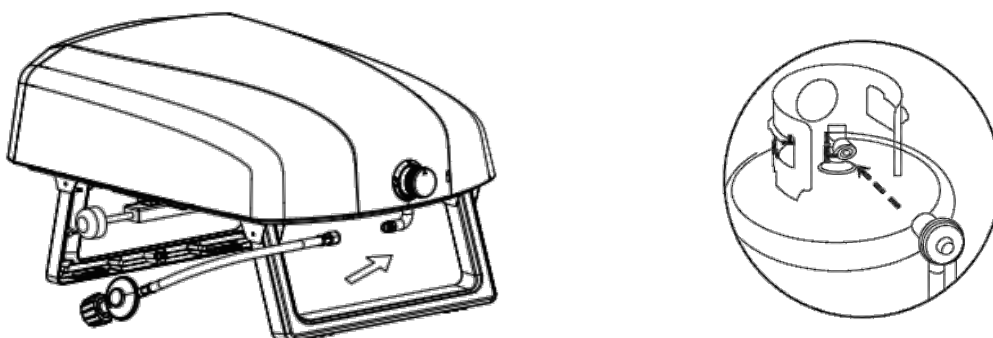

## WARNING

- Please always keep the gas bottle in upright position.
- If the appliance is not in use, the gas must be turned OFF at the supply cylinder.
- The cylinder used must include a collar to protect the cylinder valve.
- The minimum distance for the appliance and the gas tank is 1m apart.

Manufacture	Guangdong Vooma Heating Equipment Co.,Ltd			 <b>2531-26</b> PIN Code: 2531DM-0118 S/N Use outdoors only. Read the instructions before using the appliance. WARNING: accessible parts may be very hot. Keep young children away. MADE IN CHINA
Add	60 Xingye North Road, Nantou Town, Zhongshan City, Guangdong Province, P.R. China			
Model	VMP-16AS			
Appliance Type	Outdoor Pizza Oven			
Gas Category	I3+(28-30/37)	I3B/P(30)	I3B/P(50)	
Gas Type	Butane	Propane	Butane, Propane or their mixtures	
Gas Pressure	28-30 mbar	37 mbar	28-30 mbar 50 mbar	
Total Nominal Heat Input	8.5kW (G30:619g/h / G31: 608g/h)			
Destination countries	BE, FR, IT, LU, IE, GB, GR, PT, ES, CY, CZ, LT, SK, CH, SI and LV	LU, NL, DK, FI, SE, CY, CZ, EE, LT, MT, SK, SI, BG, IS, NO, TR, HR, RO, IT, HU and LV.	DE, AT, CH, SK, LU	

## IMPORTANT:

Read the following instructions carefully and be sure your gas pizza oven is properly installed, assembled and cared for. Failure to follow these instructions may result in serious bodily injury and/or property damage.

If you have any questions concerning assembly or operation, consult your dealer or LPG Gas Company.  
When used on the ground always place the appliance and cylinder on flat level ground.

**Your gas pizza oven can be used with gas cylinders between 11 kg and 15 kg. The maximum size of the gas cylinder should be: Dia. 320mm, Height: 600 mm. Follow the technical information as stated in the instruction manual and Check with your local gas supplier to have a suitable gas cylinder for your pizza.**

**NOTE FOR CONSUMER: Retain for future Reference**

## CONNECTING THE GAS CYLINDER TO THE APPLIANCE

This appliance is only suitable for use with low-pressure butane or propane gas or LPG mixtures, fitted with the appropriate low-pressure regulator via a flexible hose.

The hose should be secured to the regulator and the appliance with hose clips. Make sure the flexible hose could not come in contact with hot surface and avoid twisting.

Use a suitable regulator that is certified to BSEN 12864 or EN 16129. Make sure the regulator and flexible hose comply with local code.

Please consult your LPG dealer for information regarding a suitable regulator for the gas cylinder.

## Regulator and Hose

Use only regulators and hose approved for LP Gas at the above pressures. The life expectancy of the regulator is estimated as 2 years.

The use of the wrong regulator or hose is unsafe; always check that you have the correct items before operating the appliance.

The hose used must conform to the relevant standard for the country of use. Worn or damaged hose must be replaced. Ensure that the hose is not obstructed, kinked, or in contact with any part of the appliance other than at its connection.

**For Flexible hose:**

Avoid twisting the flexible tube when the appliance is in use. The length of flexible hose shall not exceed 1.5m. In Finland, the length shall not exceed 1.2m. The hose should be certified according to applicable EN Standard and comply with local code.

**Storage of Appliance**

Storage of an appliance indoors is only permissible if the cylinder is disconnected and removed from the appliance. When the appliance is not to be used for a period of time it should be stored in its original packaging and stored in a dry dust free environment.

**Gas Cylinder**

The gas cylinder should not be dropped or handled roughly! If the appliance is not in use, the cylinder must be disconnected. Replace the protective cap on the cylinder after disconnecting the cylinder from the appliance. The gas cylinder must be sited outside the body of the appliance.

Always connect or replace the cylinder in a well-ventilated area and away from any source of ignition, never in the presence of a flame, spark or heat source. Cylinders must be stored outdoors in an upright position and out of the reach of children. The cylinder must never be stored where temperatures can reach over 50°C. Do not store the cylinder near flames, pilot lights or other sources of ignition. **DO NOT SMOKE.**

This gas pizza oven is designed for use outdoors, away from any flammable materials. It is important that there are **no overhead obstructions** and that there is a minimum distance of 1 m from the side or rear of the appliance. It is important that the ventilation openings of the appliance are not obstructed. The appliance must be used on a level, stable surface. The appliance should be protected from direct draughts and shall be positioned or protected against direct penetration by any trickling water (e.g. rain).

**Make sure that the gas cylinder compartment (if any) is not obstructed, keep it ventilated and clean.**

**Parts sealed by the manufacturer or his agent must not be altered by the user. No modifications should be made to any part of this pizza oven and repairs and maintenance should only be carried out by a registered service engineer.**

**Connection to Appliance**

Before connection, ensure that there is no debris caught in the head of the gas cylinder, regulator, burner and burner ports. Spiders and insects can nest within and clog the burner/venturi tube at the orifice. A clogged burner can lead to a fire beneath the appliance.

Fit the hose to the appliance using a spanner to tighten it onto the connection thread. If the hose is replaced it must be secured to the appliance and regulator connections with hose clips. Disconnect the regulator from the cylinder (according to the directions supplied with the regulator) when the appliance is not in use.

The appliance must be used in a well ventilated area. Do not obstruct the flow of combustion air to the burner when the appliance is in use. **ONLY USE THIS GAS PIZZA OVEN OUTDOORS.**

**BEFORE USE CHECK FOR LEAKS**  
**Never check for leaks with a naked flame, always use a soapy water solution**

**TO CHECK FOR LEAKS**

Make 2-3 fluid ounces of leak detecting solution by mixing one part washing up liquid with 3 parts water.

Ensure the control valve is "OFF".

Connect the regulator to the cylinder, and then turn on the gas supply.

Brush the soapy solution onto the hose and all joints. If bubbles appear you have a leak, turn off the gas supply at the gas cylinder immediately.

Check the tightness of connections. If leak can not be stopped, do not try to repair. Call for replacement parts.

Always turn off the gas at cylinder after performing leak test.

**Lighting Instructions**

1. Ensure well ventilation before lighting the burner.
2. Make sure the knob is in the "OFF" position. Then push the control knob and slowly turn the knob anticlockwise to "HI" position for 5 seconds until you hear a click and the burner ignites (A). If not, please repeat this process.
3. You can adjust the fire from HI to LOW by slowly turn the control knob anticlockwise (B)
4. Please turn the control knob to "HI" position, then push the knob and clockwise to "OFF" position to turn off your pizza oven. (C)
5. If the burner has not lit after retrying wait 5 minutes and repeat step 2.

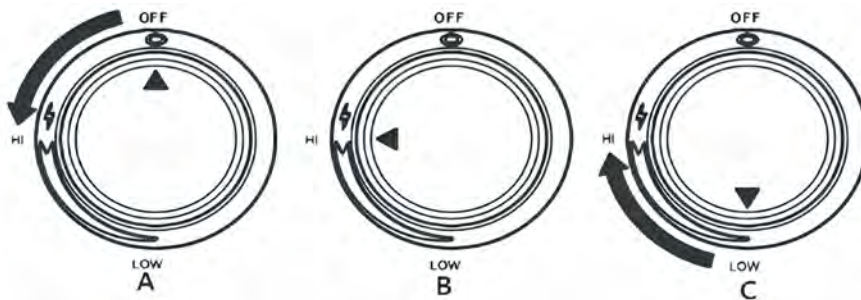

**360 degrees rotating**

The pizza oven with 360 degrees rotating pizza stone for a crispy bottom and even bake;

When you cooking a pizza, the side knob will help you to turning the pizza 360° forward and reverse.

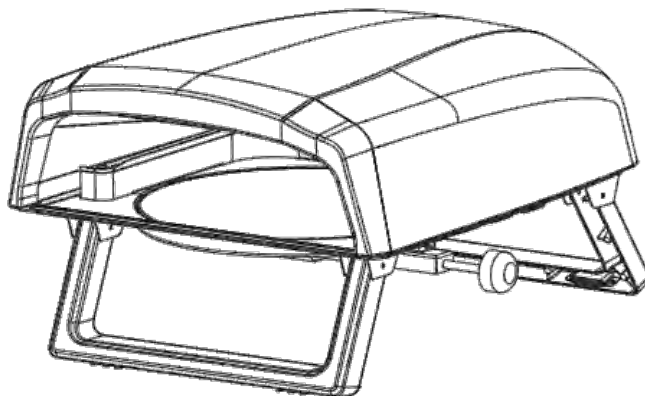

## Lighting by match

1. Make sure the knob is in the "OFF" position.
2. Push down the knob and keep pressing whilst turning anti-clockwise to the "HIGH" position (a clicking sound is heard), put the lighted match near the ports of the burner, this will light the burner. Observe if the burner has lit, if not repeat this process.
3. Adjust the heat by turning the knob to the High/Low position.
4. To turn the pizza oven 'OFF' turn the cylinder valve or regulator switch to the 'OFF' position and then turn the control knob on the appliance clockwise to the 'OFF' position.

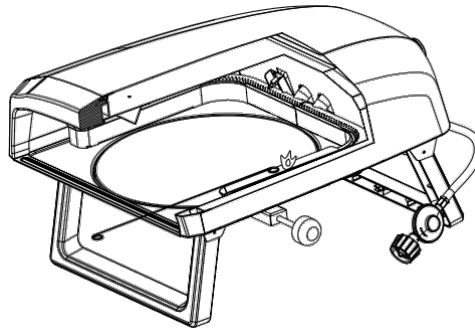

**Warning:** If the burner fails to ignite, turn the control knob off (clockwise) and also turn the cylinder valve off. Wait five minutes before attempting to relight with ignition sequence. Before cooking for the first time, operate the pizza oven for about 15 minutes and the gas turned on LOW. This will "heat clean" the internal parts and dissipate odour from the painted finish.

## AFTER COOKING

To turn the gas pizza oven off, it is best to turn off the cylinder first, and allow all the gas remaining in the hose to burn off, this will only take a couple of seconds. Then turn off burner.

While the pizza oven is cool down, then remove the pizza stone and stock it well for next using.

It is recommended that protective gloves (eg oven gloves) be used when handling particularly hot components.

## CLEANING AND CARE

### CAUTION:

- 1) All cleaning and maintenance should be carried out when the pizza oven is cool and with the fuel supply turned "OFF" at the gas cylinder.
- 2) Store Pizza oven out of direct sunlight and indoors where possible and when storing for extended periods of time. The pizza oven should not be exposed to harsh weather conditions such as snow, heavy rain and strong winds.
- 3) Wait for the pizza oven to cool completely before moving.

## Pizza Baking Stone

- DO NOT USE the stone over an open flame.
- Avoid extreme temperature change to the stone. DO NOT place frozen foods on a hot stone.
- The stone is fragile and can break if bumped or dropped.
- The stone is very hot during use and stays hot for a long time after use.
- DO NOT cool the stone with water when the stone is hot.
- After cleaning the stone with water, please dry the stone before use. This can be done in a conventional oven at 60°C (140°F) for 2 hours.

### Maintenance:

- keeping appliance area clear and free from combustible materials, gasoline, and other flammable vapors and liquids;
- not obstructing the flow of combustion and ventilation air;
- keeping the ventilation opening(s) of the cylinder enclosure free and clear from debris;
- cleaning appliance, including special surfaces, with recommended cleaning agents, if necessary;
- checking and cleaning burner tubes for insects and insect nests. A clogged tube can lead to a fire beneath the appliance;

**Your pizza oven will look better and last longer if you keep it clean.**

## **CARE AND MAINTENANCE**

Apart from cleaning , your gas pizza oven is a fairly low maintenance item. A couple of things are worth looking at through. Remember to turn off and disconnect the gas before any maintenance is carried out.

1. If your gas pizza oven uses a flexible hose to connect to the gas, check the rubber O-ring on the regulator end of the hose assembly at least once a year. If it appears worn or cracked, have it replaced.
2. If you use a portable LPG gas cylinder, you will need to have the cylinder serviced or replaced every ten years. The date of the last service should be stamped on the neck of the bottle.
3. A rain cover is also recommended to cover your gas pizza oven and maintain and protect from all weather conditions.

## **SERVICING**

Your pizza oven should be serviced annually by a competent registered person. Any modification of appliance may be dangerous.

If a replacement is necessary, please contact either our Customer Service Department or your local dealer.



Grilldepot.hu  
Signdepot Europe Kft.  
Hungary 5100 Jászberény, Alkotás utca 4/D  
+36 20 5032655  
sales@grilldepot.hu